

## Industrial Vacuum # 1

- Belt drive increases fan speed
- Large container for collecting dust
- Flexible plastic hose for ease of use

### Applications:

- Collecting dust or other particles in a factory situation
- Use for cleaning machines etc. in industry

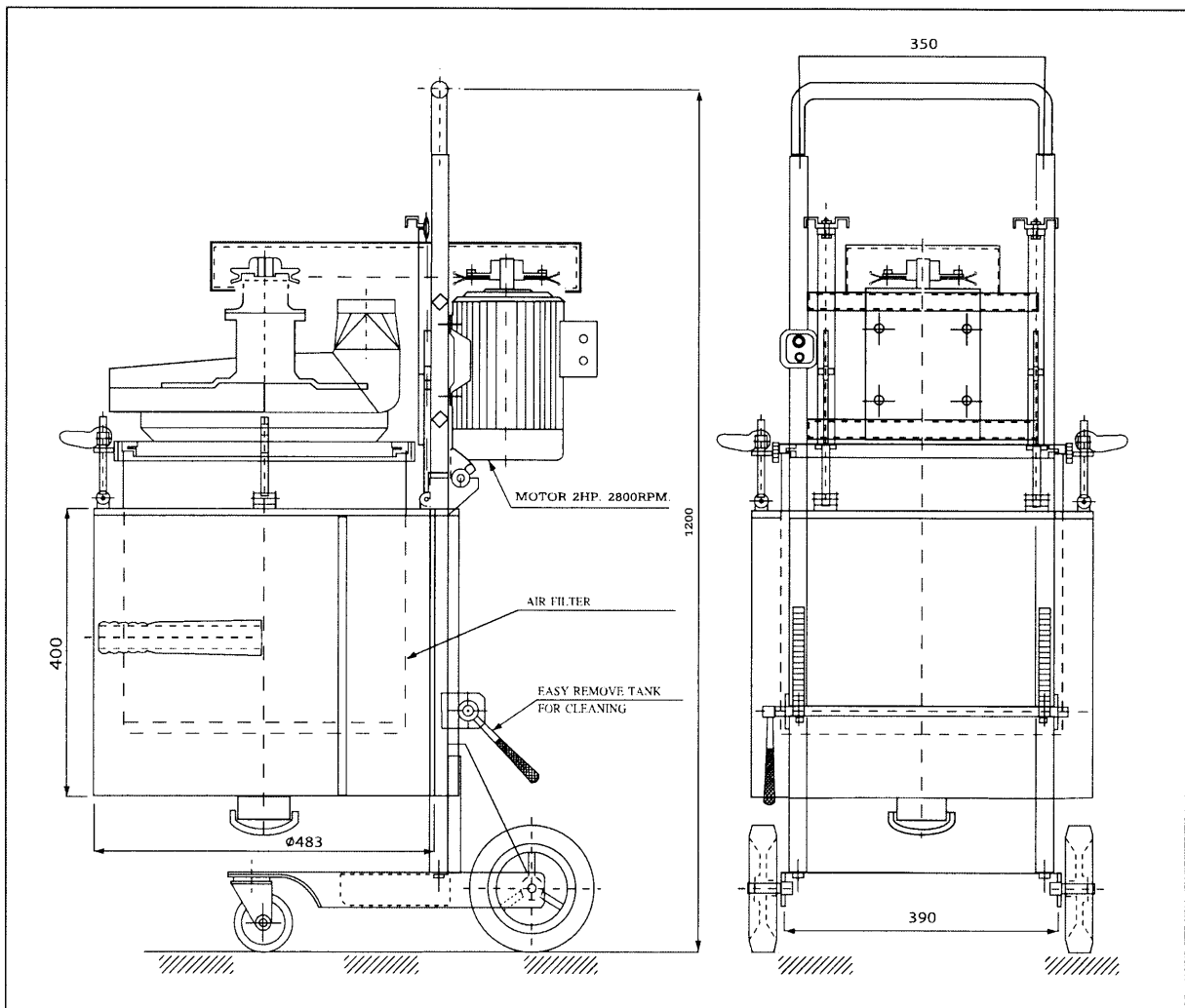

MODEL	POWER			CMM	FILTER SURFACE (CM <sup>2</sup> )	CAPACITY (CM <sup>3</sup> )
	HP.	RPM.	V.			
AV-D1213	2	2,800	380	3	14133.6	1151.5

### Industrial Vacuum # 6

1. MOTOR 3HP / 2P. (2,800 RPM.) 380V.	1	Pcs.
2. Chamber Capacity	60	Litres
3. Filter Surface Area	2	sq.m.
4. Depression	2,000	mm.Aq.
5. Air Flow	5	CMM.
6. Weight	80	kg.
7. Noise	90	dB.
8. No.of Suction Flang	2	pcs.
9. Length of Hose	5	m.

